

IW-5900 Series Installation Instruction

Installation Guidelines:

- The IW-5900 is a glass-mounted antenna. It is designed to be mounted on the interior side of the vehicle's window.
- For best performance the antenna should be mounted on an angled window with the arrow pointing down. If a front windscreen is chosen, avoid obstructing the driver's view of the road or the rear view mirror. If the rear window is chosen, avoid covering the defroster wires.
- The installation should not be attempted in temperatures less than 60° F (15.5° C). The glass must be clean and dry and antenna parts should be at room temperature.

Installation Steps:

- Clean the area on the inside of the window where the antenna will be mounted with the enclosed alcohol pad and allow it to dry thoroughly.
- Remove the protective adhesive backing from the antenna, leaving the tape on the unit. While looking through the glass from the inside, carefully place the antenna on the window, as high up near the top as possible with the arrow facing down.
- Press the antenna FIRMLY and EVENLY all around the glass. Route the cable neatly and connect to your equipment.

Cable jumpers are available from Mobile Mark.

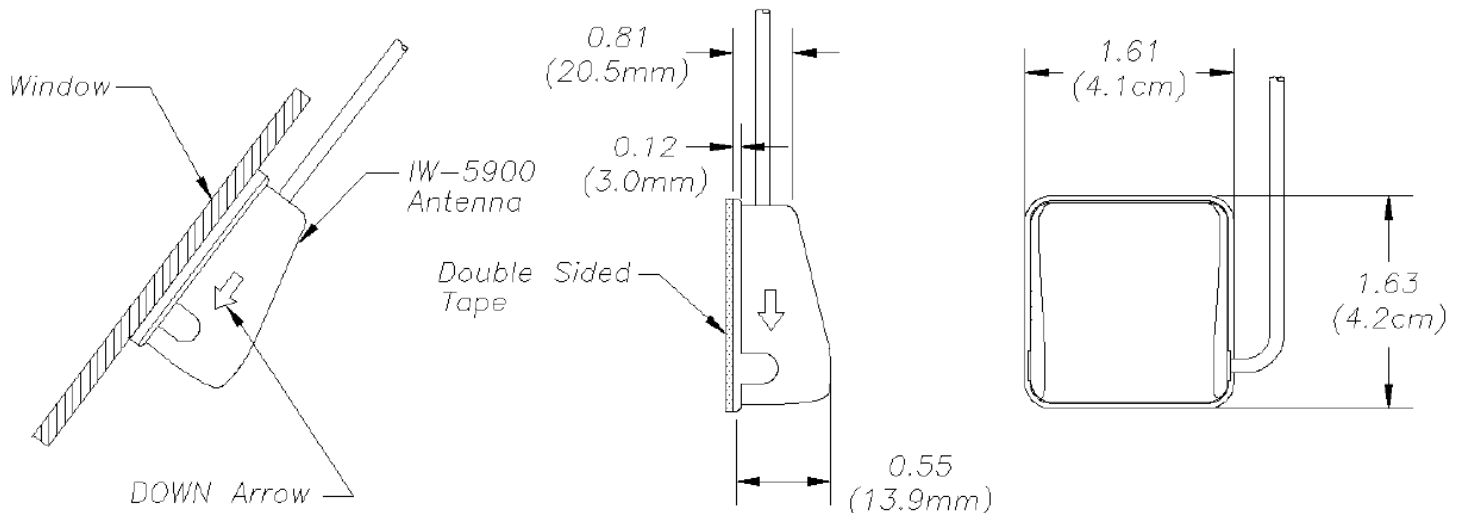

[Terms and Conditions](#)



Toll Free: 1-800-648-2800
Phone: 1-847-671-6690
Fax: 1-847-250-5120
Email: info@mobilemark.com



Phone: +44 1543 459555
Fax: +44 1543 459545
Email: enquiries@mobilemarkeurope.co.uk



Mobilemark.com

950-114-9-001-1224